

Supplemental Specifications

Section 1 - Specifications

1.01R Workmanship And Materials

This project is to be constructed utilizing [Hillsborough County Public Works Standard Specifications for Construction October 2017 Edition](#); [FDOT Standard Plans 2019-2020](#); [FDOT Standard Specifications for Road and Bridge Construction January 2020](#); with the exception of Division I and Division II Sections 100 through 103 and 105; [Hillsborough County Public Utilities Specifications for Construction October 2017](#) and [Technical Manual](#); Hillsborough County Stormwater Technical Manual; Tampa Electric Company Standard Electric Service Requirements, latest edition, available from Tampa Electric Company; and the Supplemental Specifications herein. Any conflict between the documents shall be resolved in accordance with the requirements of the Hillsborough County General Terms and Conditions.

With the exception of the Specifications contained herein and the [Hillsborough County Public Utilities Specifications for Construction October 2017](#), Hillsborough County Public Works has adopted the Florida Department of Transportation's Standard Specifications for Roadways and Bridges [FDOT Standard Plans 2020-2021](#); [FDOT Standard Specifications for Road and Bridge Construction January 2020](#) (**Turquoise with black lettering**) for use on Public Works Construction Projects, with the following exceptions/clarifications:

- A. FDOT Standard Specifications for Road and Bridge Construction Division I, Sections 1 through 9 and Division II Sections 100 through 103 and 105 are omitted from this contract and replaced in their entirety by Hillsborough County's General Terms and Conditions and Standard Specifications 01010 through 01700. References contained in Division II and Division III of the FDOT Standard Specifications related to Division I shall be replaced with the appropriate corresponding Article(s) or Technical Specifications referenced above. References to FDOT Division I Specification(s) that do not have a corresponding Article(s) or Technical Specification shall be clarified by the **COUNTY**'s Project Manager.
- B. *Paragraph Not Applicable.*
- C. The following FDOT Standard Specifications for Roadways and Bridges are replaced and/or modified with the corresponding Hillsborough County Standard Specification sections contained herein:
 - 204 Graded Aggregate Base
 - 283 Reclaimed Asphalt Pavement Base
 - 320 Hot Bituminous Mixtures; Plant, Methods and Equipment,
 - 327 Milling of Existing Asphalt Pavement,
 - 330 Hot Bituminous Mixtures General Construction Requirements,
 - 334 Superpave Asphalt Concrete,
 - 336 Asphalt Rubber Binder,
 - 337 Asphalt Concrete Friction Courses,
 - 341 Asphalt Rubber Membrane Interlayer,
 - 600 Traffic Signal Overview
 - 603 General Requirements for Installation and Evaluation of Traffic Control Equipment and Material
 - 611 Signal Installation Acceptance Procedures
 - 620 Signal Installation Grounding

630	Conduit
632	Signal and Interconnect Cable
634	Span Wire Assembly
635	Pull and Junction Boxes
639	Electrical Power Service Assemblies
650	Vehicular Signal Assemblies
652	24/7 Solar Flashing Beacon Assembly
653	Pedestrian Signal Assemblies
660	Inductive Loop Detectors
662	3-M Opticom™ Priority Control Preemption Detection
665	Pedestrian Detector Assembly
670	Traffic Controller Assembly
676	Controller Cabinets
699	Internally Illuminated Signs
901	Coarse Aggregate,
902	Fine Aggregate,
916	Bituminous Materials, and
919	Ground Rubber Tire.

The **CONTRACTOR** Quality Control requirements outlined in these Sections are required as described herein.

- D. **CONTRACTOR** Quality Control (CQC) program requirements referenced within the FDOT Standard Specifications are not required on Hillsborough County projects. However, the **CONTRACTOR** is responsible for constructing the project in accordance with the contract documents and ensuring compliance with the specifications. Therefore, the **CONTRACTOR** is responsible for scheduling and performing testing as required to ensure contract compliance. All testing performed by the **CONTRACTOR** must be performed by a FDOT qualified testing laboratory approved by the **COUNTY**. The **COUNTY** will perform Quality Assurance testing to ensure **CONTRACTOR** compliance with the contract documents. This testing is solely for the **COUNTY**'s benefit. The **COUNTY**'s testing is not intended to relieve the **CONTRACTOR** of performing testing and they are not permitted to rely on this testing to ensure their contract compliance. Quality Assurance testing by the **COUNTY** in no way relieves the **CONTRACTOR** or their Subcontractors of their responsibility to provide quality materials and workmanship on the project. No act or omission on the part of the **COUNTY**, Professional, any inspector(s), or representative of the **COUNTY** shall be construed as relieving **CONTRACTOR** of this responsibility.

- E. If the **CONTRACTOR** desires to utilize materials, means, or methods which in accordance with the FDOT specifications requires Quality Control testing and approval by the Engineer, the testing shall be performed at the expense of the **CONTRACTOR** , and reviewed for acceptance by the **COUNTY**. The **COUNTY** also reserves the right to require testing above and beyond the FDOT specified LOT testing in situations when the testing of LOT quantities will not provide a reasonable assurance of the quality of the work. This additional testing by the **CONTRACTOR** will be at no additional cost to the **COUNTY**.

- F. At the **CONTRACTOR**'s option he may submit a Value Engineering Change Proposal, also know as a Cost Savings Initiative Proposal (CSIP), or hereinafter referred to as a VECIP or CSIP in accordance with FDOT Standard Specifications for Road and Bridge Construction, Section 4-3.9, Value Engineering Incentive, or

Cost Savings Initiative Proposal. The **COUNTY** reserves the right to reject at its discretion any VECP or CSIP submittal and the **CONTRACTOR** shall remain obligated to perform the **WORK** in accordance with the terms of the existing Contract.

G. *Paragraph Not Applicable.*

H. The use of the term “Department” in the FDOT Specifications is replaced by **COUNTY** except in those instances where the FDOT is the controlling organization.

I. The terms Engineer, Project Manager and Project Representative are interchangeable between the various Contract Documents.

J. Control of Materials: The County will accept approved FDOT Quality Product List (QPL) products and materials unless stated to the contrary herein.

1.02 Project Sign

Project identification sign(s) shall be provided, placed, and removed by the **COUNTY**.

1.03R Schedule

The **CONTRACTOR**'s project schedule shall encompass the project's entire construction duration specified in the **CONTRACT** and may not indicate a shorter duration. Additionally, the schedule shall reflect the construction phasing specified in the **CONTRACT** and shall include all **WORK**, including work to be performed by others such as coordination, material acquisition, utility relocation, **COUNTY** submittal reviews, permit reviews and approvals, etc.

Bar Chart: The bar chart schedule as described in Section 01310 of the Standard Specifications shall not be required under this contract.

CPM: The CPM schedule as described in Section 01311 of the Standard Specifications shall be required under this contract.

1.04R Special Working Hours

Refer to Section 01010-1.17 of the Standard Specifications

1.05 Clearing & Grubbing

Clearing & Grubbing shall be performed in accordance with FDOT Specification Section 110. Additionally, specified plowing of the surface shall include the removal of the top layer of organic material beginning from the original ground line and if applicable stockpiling of the material for future use on the project. No additional compensation shall be provided for this **WORK** or associated **WORK**.

1.06 Pedestrian Facilities

A. All pedestrian facilities shall be constructed in accordance with the Americans with Disabilities Act (ADA) and the Department of Transportation Regulation 49 CFR, Part 37.

B. Sidewalks and curb ramps shall be constructed in accordance with the FDOT Design Standards 2010 (or the latest edition at time of bid opening) Index 304. Residential sidewalks adjacent to driveways shall be six (6) inches depth up to the first construction joint, which shall be a distance of five (5) feet measured from the edge of the driveway.

Sidewalks/Ramps adjacent to roadways shall be six (6) inches in depth up to the first construction joint which shall be a minimum distance of six (6) feet measured from the edge of pavement, or back of curb. The construction joint may not transect the detectable warning surface.

- C. Detectable warning surfaces, as defined by the latest edition of FDOT Standard Specifications for Road and Bridge Construction - Specification 527, will be utilized in lieu of tactile surfaces. Detectable warning surfaces must be capable of supporting vehicular traffic and no waivers to the warranty are acceptable. All references to tactile surfaces in the Hillsborough County Standard Specifications for construction shall be interpreted as referring to detectable warning surfaces. In order to meet ADA visual contrast requirements, the standard color for application on Hillsborough County maintained roads is red, unless otherwise directed by the Project Manager. If field conditions exist in which red would not create sufficient contrast, the Project Manager should be notified in order to determine if another color should be utilized. On FDOT maintained roads, the color requirements may vary and should be confirmed prior to placement.

- D. Typical Layout of Ramp Pay Item is below:

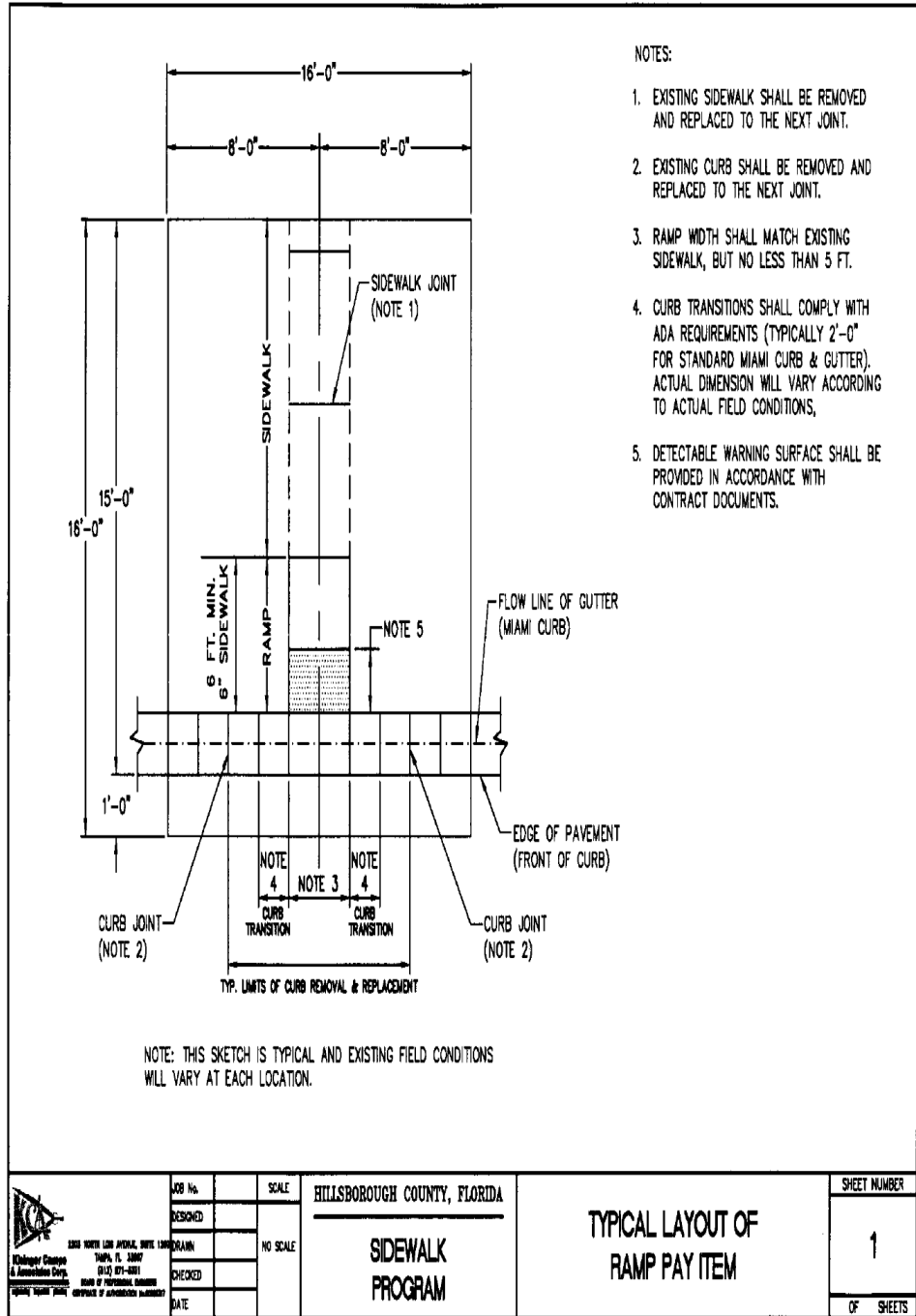

<p>2800 NORTH LANE AVENUE, SUITE 100 TALLAHASSEE, FL 32307 904.871-4001 HILLINGER GROUP & ASSOCIATES CORP. A DIVISION OF HILLINGER GROUP</p>	JOB No.	SCALE	HILLSBOROUGH COUNTY, FLORIDA	SHEET NUMBER
	DESIGNED		<p>SIDEWALK PROGRAM</p>	<p>TYPICAL LAYOUT OF RAMP PAY ITEM</p>
	DRAWN	NO SCALE		
	CHECKED			
DATE				1
				OF SHEETS

- End of Section -

Section 2 – Project Specific

2.01R Office Facilities No field offices are required.

2.02R Superpave Asphalt Unit of Measure (not applicable)

2.03R Environmental Project Signs

CONTRACTOR shall provide 0 project sign(s) for the **COUNTY**. Project sign(s) shall be fabricated, painted, and lettered in accordance with the Special Conditions if the project is financed entirely by the **COUNTY**, or in accordance with the EPA Supplementary General Conditions if partially financed by an EPA grant. Each sign shall be erected in a location as directed by the **PROJECT MANAGER**. Each sign shall be braced to keep it in a plumb position for the construction duration. **CONTRACTOR** shall remove and dispose of the sign(s) when directed by the **PROJECT MANAGER**.

2.04R Construction Phasing

Construction phasing is provided for informational purposes only. The **CONTRACTOR** is responsible for developing the project Construction Phasing Plan/Maintenance of Traffic Plan and associated coordination with Utilities, Agencies, affected land owners, etc. The **CONTRACTOR** shall maintain one lane of traffic in each direction. Additionally, the **CONTRACTOR** shall maintain all existing auxiliary turn lanes throughout the duration of the project, even during temporary traffic shifts.

2.05R Temporary Loop Detectors (not applicable)

2.06R Geotechnical Information – (not applicable)

A. Geotechnical information has been provided for the project as part of these Contract Documents. This information is being provided for the Bidder's information only and is not intended to be a complete description of the subsurface conditions. The Bidder or the **CONTRACTOR** is not relieved of any duty as otherwise required in these Contract Documents to examine the site of the proposed work or to make any investigations or inquiries, including, but not limited to additional subsurface testing, because the **COUNTY** has provided this information. Any such examinations, investigations, inquiries or testing performed by the Bidder or **CONTRACTOR** shall be done at such Bidder's or **CONTRACTOR**'s own expense.

B. Any reports provided are for the **CONTRACTOR**'s general information. The **COUNTY** disclaims all responsibility for the findings and interpretations expressed in the reports by the testing laboratories. The **CONTRACTOR** shall make whatever subsurface and geotechnical investigations it deems necessary as to actual field conditions and to comply with the requirements of the Contract Documents.

2.07R Utility Coordination – Attachment A

Any conflicts between the **WORK** that the **CONTRACTOR** shall perform and the utility owner's facilities shall be resolved by the **CONTRACTOR** and the utility owner with the **COUNTY'S** concurrence. Utility Relocation Schedules and timelines included in the Contract Documents are intended to demonstrate the relationship between the utility relocation phasing plans and the construction phasing plans developed during the design of the project.

2.08R Permits – Attachment B

A. Pursuant to the General Conditions, the **COUNTY** has obtained the following permits:

Bridge 104101 Morris Bridge Road over Bassett Creek

1. *Environmental Resource General Permit from SWFWMD
Permit No:47044319.000*
2. *USACE SAJ-2019-04333-EWG Authorization Received Feb 18, 2020 (NWP 3)*

Bridge 104405 Morris Bridge Road over New River

3. *Environmental Resource General Permit from SWFWMD
Permit No. 47044318.000*
4. *USACE SAJ-2019-04334-EWG. Authorization Received 2-18-2020 (NWP 3)*

Bridge 100026 Morris Bridge Road over Hillsborough River

5. *Environmental Resource General Permit from SWFWMD
Permit No. 47044313.000*
6. *USACE SAJ-2019-03501-PTR Authorization received 12/18/2019 (NWP 3)*

B. Pursuant to section 218.80, Florida Statutes, Hillsborough County discloses that the permits and fees listed below are the responsibility of the **CONTRACTOR**.

<u>PERMIT</u>	<u>COST</u>
Hillsborough County Right of Way Use Permit	\$ 00.00
NPDES Notice of Intent	
Note: Less than 1 acre not required	
1-5 acres	\$250.00
Over 5 acres	\$400.00
Hillsborough County Temporary Traffic Control Permit	\$ 00.00

An Allowance of \$250.00 has been included in the bid proposal section to reimburse the **CONTRACTOR** for the cost of permits, in accordance with Items 4.f (Permits) and 9.d (Cash Allowance) of the General Terms and Conditions. Any unused allowance remaining at the end of the Contract will be credited back to the **COUNTY** by Change Order.

- End of Section -